

Innovative vacuum for automation



**MILLSOM**  
VACUUM HANDLING

**Schmalz Suction Pads - SPxx**  
Long Lasting pads for packaging applications  
made from "Elastodur"

# Suction pads for packaging

SPF, SPB1, SPOB1

## Modular design

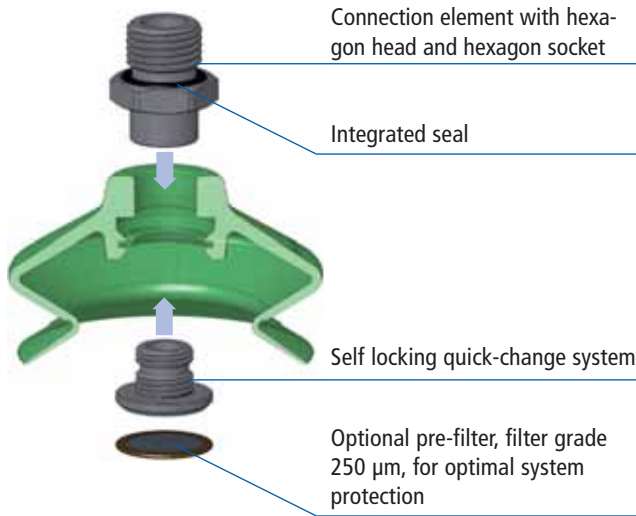

## Flexible and durable

The new generation of suction pads for cardboard and rigid packaging features an extremely soft and adaptable sealing lip in combination with a robust reinforced main body. The entire series of flexible and robust packaging suction pads is made from the new, wear-resistant material ELASTODUR, which is characterised by its long life and excellent elasticity.

## Special highlights

- Reduced energy consumption due to outstanding sealing properties
- High horizontal and vertical force due to maximum suction diameter and "interlocking" sealing lip and bellows
- Long life time due to the deployment of a new highly wear resistant material ELASTODUR

## Bellows suction pad SPB1 (round), 1,5 folds - Ø20, Ø25, Ø30, Ø40, Ø50, Ø60

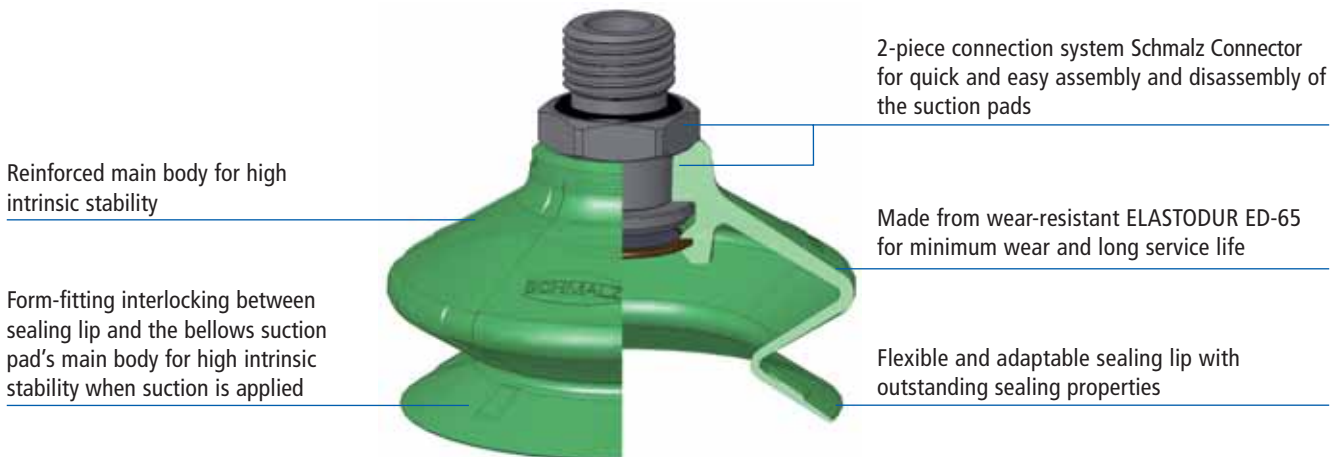

## Flat suction pad SPF (round) - Ø20, Ø25, Ø30, Ø40, Ø50

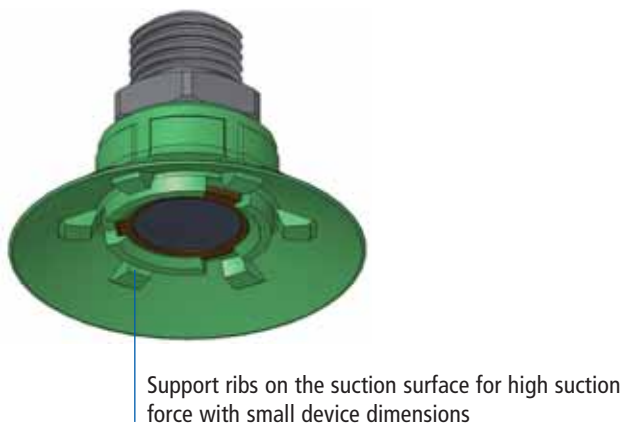

## Bellows suction pad SPOB1 (oval), 1,5 folds

60x20, 100x40, 150x60

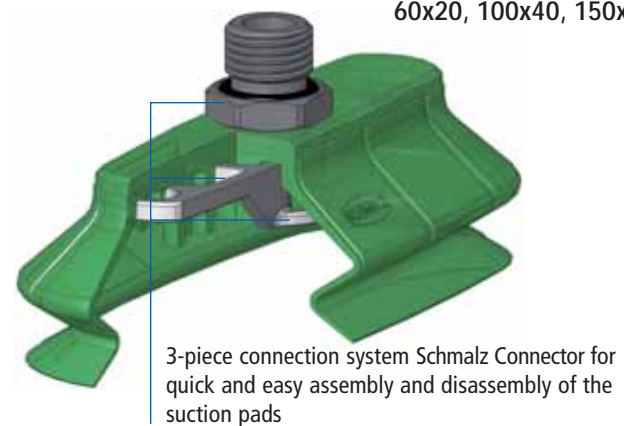

Australian Distributor: