

VACUMASTER 250-90° swivelling

Maximum load 250 kg

Technical Catalogue

VM 04/04



J. Schmalz GmbH
 Acher Straße 29 · D-72293 Glatten
 Phone +49 (74 43) 24 03-301, Fax -399
 Internet: www.vacuworld.com
 E-mail: schmalz@schmalz.de

VACUMASTER 250-90°: complete units (400 V versions)

Type	Handlebar length	Pump capacity	Qty.	Suction pad		Mounting	Length of main beam	Own weight	Article No.
				Ø	Type				
VACUMASTER 250-90-4	860 mm	6 m³/h	4	360 mm	SPU	flexible	1800 mm	111 kg	12.02.08.00604
VACUMASTER 250-90-8	860 mm	6 m³/h	8	210 mm	SPU	flexible	1800 mm	118 kg	12.02.08.00072

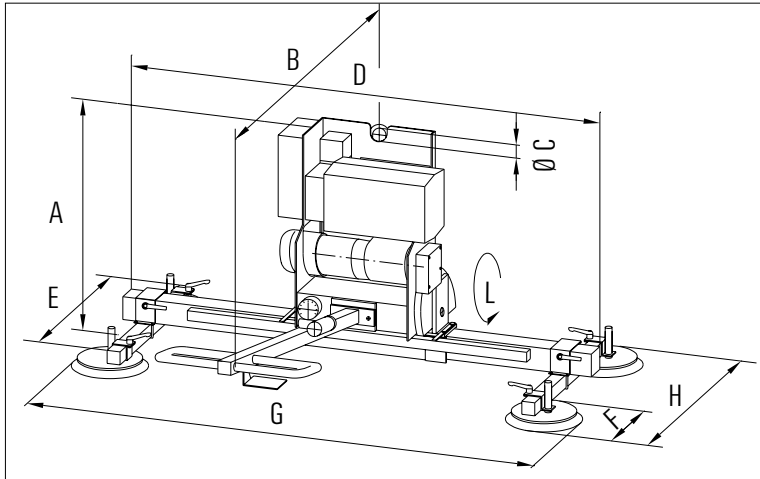

VACUMASTER 250-90°: technical data and dimensions

Number of suction pads	1	2	4	4	6	8
Type of suction pad	SPU (standard)	SPU (standard)	SPU (standard)	SPK (special)	SPU (standard)	SPU (standard)
A Overall height	–	–	780 mm	780 mm	–	780 mm
B Handlebar length	–	–	860 or 1200 mm	860 or 1200 mm	–	860 or 1200 mm
C Crane eye	–	–	Ø 52 mm	Ø 52 mm	–	Ø 52 mm
D Length of main beam	–	–	Standard: 1800, 2400 or 3000 mm			
E Length of cross beam	–	–	800 mm	800 mm	–	800 mm
F Suction pad diameter	–	–	Ø 360 mm	Ø 250 mm	–	Ø 210 mm
Surface of the load	–	–	smooth, slightly rough	rough or structured	–	smooth, slightly rough
Type of suction pad mounting	–	–	flexible	flexible	–	flexible
G x H Minimum suction pad spacing (outer edges)	–	–	980 x 660 mm	870 x 500 mm	–	1250 x 420 mm
G x H Maximum suction pad spacing (outer edges)	–	–	G = beam length D plus suction pad diameter F H = beam length E plus suction pad diameter F minus 80 mm			
L Swivelling angle	–	–	90°	90°	–	90°
Swivelling duration 90°	–	–	3–5 sec	3–5 sec	–	3–5 sec
Max. workpiece thickness	–	–	120 mm	120 mm	–	120 mm

Ordering data

Component: basic body

Type	Weight	Article No.
BK VM 125/250-90	50 kg	12.02.08.00001

Component: handlebar

Type	Length	Weight	Article No.
BB VM-KPL-860-F3/8	860 mm	5.5 kg	12.02.07.00118
BB VM-KPL-1200-F3/8	1200 mm	6.8 kg	12.02.07.00119

Selection aids

Basic body

Type	Available power supply
Please indicate when ordering	3– 200–230 V (Δ) 50 Hz; 200–250 V (Δ) 60 Hz
Standard	3– 346–400 V (Y) 50 Hz; 346–460 *V (Y) 60 Hz

* 430-460 V (Y) 60 Hz needs transformer (see page 28)

Handlebar

Length	Max. workpiece width
860 mm	up to 1720 mm
1200 mm	up to 2400 mm

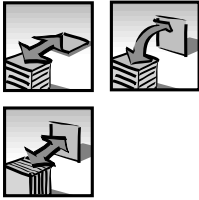

VACUMASTER 250-90° swivelling

Maximum load 250 kg

Technical Catalogue
VM 04/04



J. Schmalz GmbH
Aacher Straße 29 · D-72293 Glatten
Phone +49 (74 43) 24 03-301, Fax -399
Internet: www.vacuworld.com
E-mail: schmalz@schmalz.de

Surface classes (for selection of the pump power and suction pad type)

Material	Type	Surface condition	Material	Type	Surface condition
Metal	M1	smooth, 1 or 2 suction pads on VACUMASTER	Glass and plastics	G1	smooth, 1 or 2 suction pads on VACUMASTER
	M2	smooth, 4, 6 or 8 suction pads/rough, slightly rusty or scaly		G2	smooth, 4, 6 or 8 suction pads on VACUMASTER
	M3	structured, (including checkerplate) or very rusty		G3	structured
Wood	H1	laminated	Stones	S1	natural stone, ground and polished
	H2	planed solid wood		S2	natural stone, flamed + broken, smooth cement
	H3	veneered wood, smoothly sawn solid wood		S3	concrete

Ordering data

Component: vacuum generator

Type	Suction capacity & Power	Weight	Article No.
VE VM-EVE 6D-90	6 m³/h; 0.25 kW	7.7 kg	12.02.08.00035
VE VM-EVE 10D-90	10 m³/h; 0.37 kW	19.2 kg	12.02.08.00006

Always indicate supply voltage when ordering!

Component: main beam

Type	Length	Weight	Article No.
MAIN BEAM-1800-VM 125/250	1800 mm	15.3 kg	12.02.07.00104
MAIN BEAM-2400-VM 125/250	2400 mm	20.2 kg	12.02.07.00105
MAIN BEAM-3000-VM 125/250	3000 mm	25.5 kg	12.02.07.00106

Component: suction-pad system

Type	Qty.	Type	Weight	Article No.
SAS VM 250-90-4 SPU 300 GEL	4	SPU	28.2 kg	12.02.08.00329
SAS VM 250-90-4 SPK 250 GEL	4	SPK	21.0 kg	12.02.08.00033
SAS VM 250-90-8 SPU 210 GEL	8	SPU	34.8 kg	12.02.08.00028

Component: vacuum distributor

Type	Length	Weight	Article No.
DISTRIBUTOR-VM-KPL30-1500	1500 mm	4.5 kg	12.02.07.00010
DISTRIBUTOR-VM-KPL30-2800	2800 mm	7.3 kg	12.02.07.00011

Selection aids

Vacuum generator: suction capacity

Suction capacity	Metal	Wood	Stone	Glass and plastics
6 m³/h	M2	H1	S1	G2
10 m³/h	M3	H2 & H3	S2 & S3	G3

Vacuum generator: electric power

Type	Suction capacity	Available supply voltage
"230 V"	6 m³/h	3- 200-255 V (Δ) 50 Hz; 200-277 V (Δ) 60 Hz
"400 V"	6 m³/h	3- 346-440 V (Y) 50 Hz; 346-480 V (Y) 60 Hz
"230 V"	10 m³/h	3- 200-240 V (Δ) 50 Hz; 200-277 V (Δ) 60 Hz
"400 V"	10 m³/h	3- 346-420 V (Y) 50 Hz; 346-480 V (Y) 60 Hz

Main beam and suction pads

Thickness	Format of sheet metal in mm							
	1000 x 2000		1250 x 2500		1500 x 3000		2000 x 4000	
	No. of pads	Main beam	No. of pads	Main beam	No. of pads	Main beam	No. of pads	Main beam
0.5 mm	4 pc.	1800 mm	8 pc.	1800 mm	8 pc.	2400 mm	8 pc.	4000 mm*
1.0 mm	4 pc.	1800 mm	8 pc.	1800 mm	8 pc.	2400 mm	8 pc.	4000 mm*
1.5 mm	4 pc.	1800 mm	8 pc.	1800 mm	8 pc.	2400 mm	8 pc.	4000 mm*
2.0 mm	4 pc.	1800 mm	8 pc.	1800 mm	8 pc.	2400 mm	8 pc.	4000 mm*
2.5 mm	4 pc.	1800 mm	8 pc.	1800 mm	8 pc.	2400 mm	8 pc.	4000 mm*
3.0 mm	4 pc.	1800 mm	8 pc.	1800 mm	8 pc.	2400 mm	8 pc.	4000 mm*
4.0 mm	4 pc.	1800 mm	8 pc.	1800 mm	8 pc.	2400 mm	8 pc.	4000 mm*
5.0 mm	4 pc.	1800 mm	4 pc.	1800 mm	8 pc.	2400 mm	-	-
6.0 mm	4 pc.	1800 mm	4 pc.	1800 mm	8 pc.	2400 mm	-	-
8.0 mm	4 pc.	1800 mm	4 pc.	1800 mm	-	-	-	-
10 mm	4 pc.	1800 mm	4 pc.	1800 mm	-	-	-	-
12 mm	4 pc.	1800 mm	-	-	-	-	-	-
15 mm	4 pc.	1800 mm	-	-	-	-	-	-

* on request

Type of suction pad

Pad type	Workpiece surface			Glass and plastics
	Metal	Wood	Stone	
SPU	M2	H1-H3	S1	G2
SPK	M3	-	S2 & S3	G3

Vacuum distributor

Distributor length	Length of main beam
1500 mm	1800 mm and 2400 mm
2800 mm	3000 mm