

VACUMASTER 125-90° swivelling

Maximum load 125 kg

Technical Catalogue
VM 04/04



J. Schmalz GmbH
Acher Straße 29 · D-72293 Glatten
Phone +49 (74 43) 24 03-301, Fax -399
Internet: www.vacuworld.com
E-mail: schmalz@schmalz.de

VACUMASTER 125-90°: complete units (400 V versions)

Type	Handlebar length	Pump capacity	Qty.	Suction pad			Length of main beam	Own weight	Article No.
				Ø	Type	Mounting			
VACUMASTER 125-90-2	860 mm	6 m³/h	2	360 mm	SPU	rigid	1800 mm	90 kg	12.02.08.00637
VACUMASTER 125-90-4	860 mm	6 m³/h	4	210 mm	SPU	flexible	1800 mm	101 kg	12.02.08.00069
VACUMASTER 125-90-6	860 mm	6 m³/h	6	210 mm	SPU	flexible	1800 mm	109 kg	12.02.08.00070

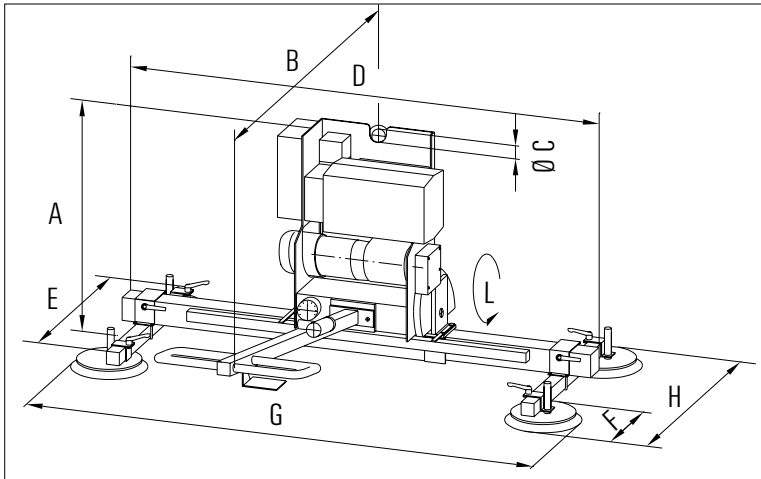

VACUMASTER 125-90°: technical data and dimensions

Number of suction pads Type of suction pad	1	2	4	4	6	8
	SPU (standard)	SPU (standard)	SPU (standard)	SPK (special)	SPU (standard)	SPU (standard)
A Overall height	–	730 mm	780 mm	780 mm	780 mm	–
B Handlebar length	–	860 or 1200 mm	860 or 1200 mm	860 or 1200 mm	860 or 1200 mm	–
C Crane eye	–	Ø 52 mm	Ø 52 mm	Ø 52 mm	Ø 52 mm	–
D Length of main beam	–	–	Standard: 1800, 2400 or 3000 mm			–
E Length of cross beam	–	–	800 mm	800 mm	800 mm	–
F Suction pad diameter	–	Ø 360 mm	Ø 210 mm	Ø 200 mm	Ø 210 mm	–
Surface of the load	–	smooth, slightly rough, slightly scaly or rusty			rough or structured	smooth, slightly rough
Type of suction pad mounting	–	rigid	flexible	flexible	flexible	–
G x H Minimum suction pad spacing (outer edges)	–	G = 870 mm	830 x 420 mm	820 x 400 mm	830 x 420 mm	–
G x H Maximum suction pad spacing (outer edges)	–	G = D + F – 100 mm	G = beam length D plus suction pad diameter F H = beam length E plus suction pad diameter F minus 80 mm			–
L Swivelling angle	–	90°	90°	90°	90°	–
Swivelling duration 90°	–	3–5 sec	3–5 sec	3–5 sec	3–5 sec	–
Max. workpiece thickness	–	180 mm	180 mm	180 mm	180 mm	–

Ordering data

Component: basic body

Type	Weight	Article No.
BK VM 125/250-90	50 kg	12.02.08.00001

Component: handlebar

Type	Length	Weight	Article No.
BB VM-KPL-860-F3/8	860 mm	5.5 kg	12.02.07.00118
BB VM-KPL-1200-F3/8	1200 mm	6.8 kg	12.02.07.00119

Selection aids

Basic body

Type	Available power supply
Please indicate when ordering	3–200–230 V (Δ) 50 Hz; 200–250 V (Δ) 60 Hz
Standard	3–346–400 V (Y) 50 Hz; 346–460 *V (Y) 60 Hz

*430-460 V (Y) 60 Hz needs transformer (see page 28)

Handlebar

Length	Max. workpiece width
860 mm	up to 1720 mm
1200 mm	up to 2400 mm

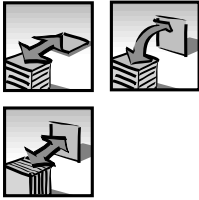

VACUMASTER 125-90° swivelling

Maximum load 125 kg

Technical Catalogue
VM 04/04



J. Schmalz GmbH
Aacher Straße 29 · D-72293 Glatten
Phone +49 (74 43) 24 03-301, Fax -399
Internet: www.vacuworld.com
E-mail: schmalz@schmalz.de

Surface classes (for selection of the pump power and suction pad type)

Material	Type	Surface condition	Material	Type	Surface condition
Metal	M1	smooth, 1 or 2 suction pads on VACUMASTER	Glass and plastics	G1	smooth, 1 or 2 suction pads on VACUMASTER
	M2	smooth, 4, 6 or 8 suction pads/rough, slightly rusty or scaly		G2	smooth, 4, 6 or 8 suction pads on VACUMASTER
	M3	structured, (including checkerplate) or very rusty		G3	structured
Wood	H1	laminated	Stones	S1	natural stone, ground and polished
	H2	planed solid wood		S2	natural stone, flamed + broken, smooth cement
	H3	veneered wood, smoothly sawn solid wood		S3	concrete

Ordering data

Component: vacuum generator

Type	Suction capacity & Power	Weight	Article No.
VE VM-EVE 6D-90	6 m³/h; 0.25 kW	7.7 kg	12.02.08.00035
VE VM-EVE 10D-90	10 m³/h; 0.37 kW	19.2 kg	12.02.08.00006

Always indicate supply voltage when ordering!

Component: main beam

Type	Length	Weight	Article No.
MAIN BEAM-1800-VM 125/250	1800 mm	15.3 kg	12.02.07.00104
MAIN BEAM-2400-VM 125/250	2400 mm	20.2 kg	12.02.07.00105
MAIN BEAM-3000-VM 125/250	3000 mm	25.5 kg	12.02.07.00106

Component: suction-pad system

Type	Qty.	Type	Weight	Article No.
SAS VM 125-90-2 SPU 360B S	2	SPU	11.3 kg	12.02.08.00328
SAS VM 125-90-4 SPU 210 GEL	4	SPU	17.6 kg	12.02.08.00026
SAS VM 125-90-4 SPK 200 GEL	4	SPK	16.7 kg	12.02.08.00032
SAS VM 125-90-6 SPU 210 GEL	6	SPU	26.2 kg	12.02.08.00027

Component: vacuum distributor

Type	Length	Weight	Article No.
DISTRIBUTOR-VM-KPL30-1500	1500 mm	4.5 kg	12.02.07.00010
DISTRIBUTOR-VM-KPL30-2800	2800 mm	7.3 kg	12.02.07.00011

Selection aids

Vacuum generator: suction capacity

Suction capacity	Metal	Wood	Stone	Glass and plastics
6 m³/h	M1 & M2	H1	S1	G1 & G2
10 m³/h	M3	H2 & H3	S2 & S3	G3

Vacuum generator: electric power

Type	Suction capacity	Available supply voltage
"230 V"	6 m³/h	3~ 200-255 V (Δ) 50 Hz; 200-277 V (Δ) 60 Hz
"400 V"	6 m³/h	3~ 346-440 V (Y) 50 Hz; 346-480 V (Y) 60 Hz
"230 V"	10 m³/h	3~ 200-240 V (Δ) 50 Hz; 200-277 V (Δ) 60 Hz
"400 V"	10 m³/h	3~ 346-420 V (Y) 50 Hz; 346-480 V (Y) 60 Hz

Main beam and suction pads

Thick-ness	Format of sheet metal in mm					
	1000 x 2000		1250 x 2500		1500 x 3000	
	No. of pads	Main beam	No. of pads	Main beam	No. of pads	Main beam
0.5 mm	4 pc.	1800 mm	6 pc.	1800 mm	6 pc.	2400 mm
1.0 mm	4 pc.	1800 mm	6 pc.	1800 mm	6 pc.	2400 mm
1.5 mm	4 pc.	1800 mm	6 pc.	1800 mm	6 pc.	2400 mm
2.0 mm	4 pc.	1800 mm	6 pc.	1800 mm	6 pc.	2400 mm
3.0 mm	4 pc.	1800 mm	6 pc.	1800 mm	6 pc.	2400 mm
4.0 mm	4 pc.	1800 mm	4 pc.	1800 mm	—	—
5.0 mm	2 pc.	1800 mm	4 pc.	1800 mm	—	—
6.0 mm	2 pc.	1800 mm	—	—	—	—
8.0 mm	2 pc.	1800 mm	—	—	—	—

Type of suction pad

Pad type	Workpiece surface			Glass and plastics
	Metal	Wood	Stone	
SPU	M1 & M2	H1-H3	S1	G1 & G2
SPK	M3	—	S2 & S3	G3

Vacuum distributor

Distributor length	Length of main beam
1500 mm	1800 mm and 2400 mm
2800 mm	3000 mm