

# Large-area vacuum gripping systems FXC/FMC

Maximum flexibility for automated handling processes

## Construction, functions and performance of the new large-area vacuum gripping systems FXC/FMC

### Large-area vacuum gripping system FXC with integrated vacuum generator

#### Basic body

- Extruded aluminium section
- Variable lengths; also variable widths by blocking together
- Protective housing for vacuum generator

#### Vacuum indicator (manometer)

#### Vacuum generator

- Lightweight, push-in ejector
- Quickly replaceable
- Alternatively with up to 4 multi-stage ejector blocks for optimum power adjustment

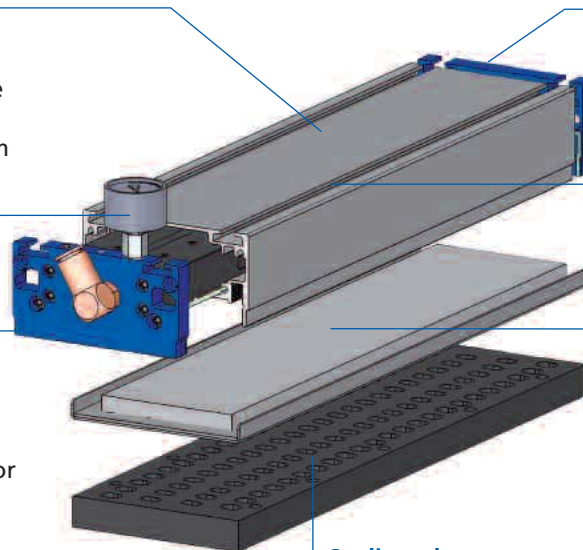

#### End cover with functional elements

- for connections "Sensor", "Blow off" and "Separate"

#### Slots

- for flexible mechanical mounting of the gripper

#### Valve module

- with valve technology SW as low-cost version
- with valve technology SVKW for short cycle times

#### Sealing plate

- flexible and hard-wearing
- various hole spacings, depending on workpiece width
- quickly replaceable

### Large-area vacuum gripping system FMC with external vacuum generator

#### Basic body

- low overall height

#### Vacuum indicator (manometer)

#### Connector for external vacuum generator

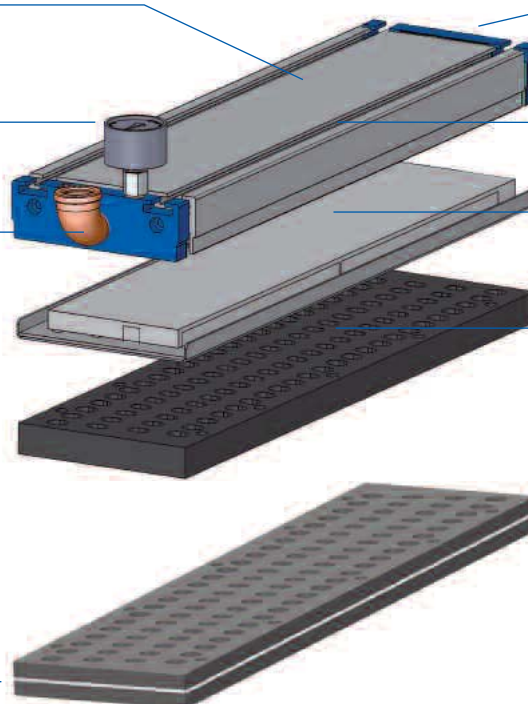

#### End cover with functional elements

#### Slots

#### Valve module

#### Sealing plate

#### Optional for FXC und FMC:

Filter mat with self-cleaning effect to protect the gripper against dirt

# Large-area vacuum gripping systems FXC/FMC

## Selection criteria

### Selection criteria for FXC/FMC

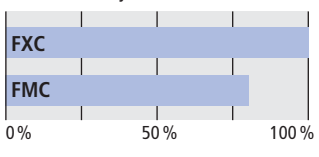
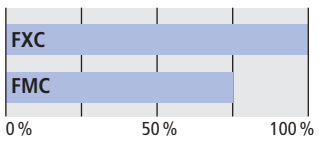
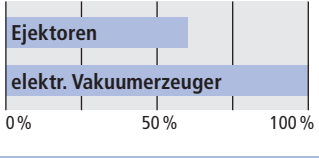
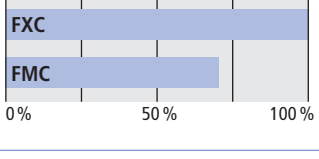
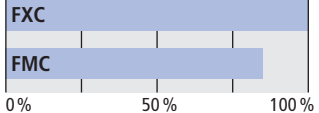
Application properties		Recommended type
<b>Vacuum generation with maximum effectiveness</b> No losses since the ejector is integrated close to the point where vacuum is needed in the gripper	Flow efficiency 	FXC
<b>Function integration and process reliability</b> Improved process reliability, with no projecting parts and no risk of damage, since there are no vacuum hoses, distributors or mounting elements between the vacuum generator and the gripper	Function integration 	
<b>Minimum system costs</b> No additional costs for installation of external vacuum generator. Ejectors cost less than electric vacuum generators, need less space and weigh less	Investment-cost comparison 	
<b>Dynamic operation and very short cycle times</b> Minimum weight and overall gripper height on robot or portal head	Gripper weight 	FMC
<b>Operation with electric vacuum generator</b> Lower operating costs by using external vacuum generators such as a vacuum pump or blower	Operating costs (energy) 	

### Selection criteria for product features FXC/FMC

Application properties	Recommended product features
Short cycle times and rough workpiece surfaces	Valve technology SVKW
Low-cost version	Valve technology SW
Very dirty surroundings; fine/sticky/moist dust	Sealing plate with integrated filter
Separation of porous objects from stacks (e.g. chipboards, MDF)	FXC/FMC with integrated separation function
Workpiece width	At least 30mm with fine hole spacing (18), 60mm with medium hole spacing (36)
Badly warped and very rough surfaces	Solution with product type SBX, see page 17
Non-rigid workpieces (e.g. goods packed in plastic film, thin cardboard boxes)	Solution with product type SSP, see page 19

### Service and practical hints

- When handling uneven layers and objects with rough surfaces, the lifting capacity and the handling safety can be improved by pressing the gripper against the workpiece and by flexible mounting of the gripper
- The operating lifetime of the sealing plate is generally 3 to 12 months if it is applied to and removed from the workpiece vertically
- Regular inspections every six months will extend the operating lifetime of the large-area vacuum gripping system
- Lifting tests with original workpieces are in all cases necessary in order to ensure correct operation. We will carry out these tests for your application free of charge