



Schmalz Large Area Gripper - FXC/FMC
Specialised gripper systems for
automated door handling solutions

Vacuum Gripper Systems

Large-area grippers FXC/FMC-DG

With customised foam pad for optimum handling of narrow workpieces.

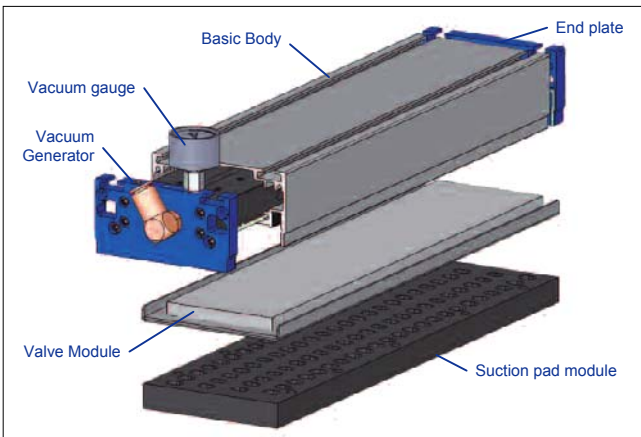

Our Highlights...

- Area gripper with advanced area of operation
- High Performance foam
- Optimized flow valves and hole spacing
- Modular design

Your Advantages...

- ▶ Flexible door handling with just 80mm door frame width
- ▶ 50% less energy consumption
- ▶ Long lifetime, quick-change replacement, dust protection by integrated filter mat
- ▶ Optimum system layout

Applications

- Handling of workpieces in various sizes and/or undefined position
- Handling of workpieces with holes or gaps
- Automated palletizing, de-palletizing, commissioning and sorting of doors
- Handling of narrow timber planks for stacking or packing
- Automated pallet manufacturing or handling

Construction

- Vacuum gripper system with integrated vacuum generator
- Body made from light-weight and rigid aluminium extrusion which incorporates two "T" slots for easy mounting
- Adaptation to a wide range of handling tasks thanks to various formats and two different principles of operation (SVK-W,SW)
- Valve technology SVK-W shuts off unused cells, ensuring maximum holding capacity to the cells being used
- Modular design permits the combination of several vacuum gripper systems to form an overall system which is perfectly matched to the intended handling task
- Foam suction pad incorporates a sandwiched section of filter material suitable for dusty environments

Ordering Data

Available on request

Availability

Available!

Design Data

