

# Spring plungers

## Spring plunger FSTE



Spring plungers FSTE

### Our highlights...

- Spring plunger with lower damping spring
- Wide range of connection threads and stroke lengths
- Anti-rotation guard available as option

### Your advantages...

- > Soft placement of the suction pad on easily damaged workpieces; good compensation for varying workpiece heights
- > For a wide range of applications; available for all suction pads of the standard program
- > Suitable for use with oval suction pads

Mounting elements  
4



Spring plungers FSTE on a vacuum spider for handling of sheet metal in the automobile industry

### Applications

- Handling of workpieces with differing heights (such as curved metal sheets, etc.)
- Handling of easily damaged workpieces (such as sheets of glass) without additional control functions to prevent damage, since the plunger ensures soft placement

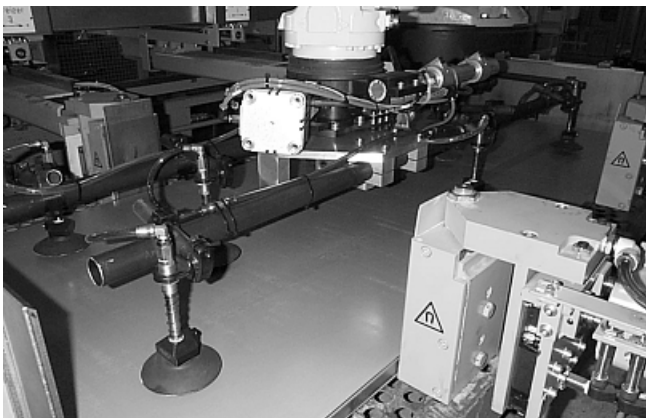

Vacuum spider with spring plungers FSTE

### Construction

- Spring plunger consisting of a high-strength steel rod, guide sleeve and upper and lower damping springs
- Plunger rod with integrated vacuum feed (connection thread at top)
- Female connection thread for suction pads up to size M5, otherwise male thread
- Thread for vacuum line is always a female thread



### Suitability for branch-specific applications

# Spring plungers

## Spring plunger FSTE



### Designation code Spring plunger FSTE

Short designation	Suction-pad connection	Plunger stroke in mm	Additional function
Example: FSTE	M3-IG	5	VG
FSTE	M3-IG (IG = female) M5-IG G1/8-AG (AG = male) G1/4-AG G1/2-AG	5 to 90	VG...with anti-rotation guard

### Ordering data Spring plunger FSTE

Type*	Plunger stroke in mm**							
	5	10	15	20	25	50	75	90
FSTE M3	10.01.02.00613	-	-	-	-	-	-	-
FSTE M3 VG	10.01.02.00614	-	-	-	-	-	-	-
FSTE M5	10.01.02.00607	10.01.02.00608	-	10.01.02.00609	-	-	-	-
FSTE M5 VG	10.01.02.00610	10.01.02.00611	-	10.01.02.00612	-	-	-	-
FSTE G1/8	-	-	10.01.02.00602	-	10.01.02.00603	10.01.02.00604	-	-
FSTE G1/8 VG	-	-	10.01.02.00605	-	-	10.01.02.00606	-	-
FSTE G1/4	-	-	-	-	10.01.02.00567	10.01.02.00568	10.01.02.00569	-
FSTE G1/4 VG	-	-	-	-	10.01.02.00570	-	10.01.02.00571	-
FSTE G1/2	-	-	-	-	10.01.02.00574	-	10.01.02.00575	10.01.02.00576

\*VG = version with rotation lock for repeatedly accurate positioning of suction pads

\*\*Commendation: To raise the lifetime in continuous duty, prevent the maximal slide stroke

### Technical data Spring plunger FSTE

Type	Spring rate [N/mm]	Spring pre-tension [N]	Spring force [N]*	Vertical load [N]**	Horizontal load [N]***	Weight [g]	Operating temperature [°C]
FSTE M3-IG 5	0,596	1,49	2,98	550	47	9	0...80
FSTE M3-IG 5 VG	0,596	1,49	2,98	550	47	9	0...80
FSTE M5-IG 5	0,508	3,30	4,57	1500	132	16	0...80
FSTE M5-IG 5 VG	0,508	3,30	4,57	1500	132	16	0...80
FSTE M5-IG 10	0,323	2,75	4,36	1500	97	19	0...80
FSTE M5-IG 10 VG	0,323	2,75	4,36	1500	97	19	0...80
FSTE M5-IG 20	0,209	1,78	3,87	1500	63	25	0...80
FSTE M5-IG 20 VG	0,209	1,78	3,87	1500	63	25	0...80
FSTE G1/8-AG 15	0,221	3,53	5,19	3700	385	80	0...80
FSTE G1/8-AG 15 VG	0,221	3,53	5,19	3700	385	80	0...80
FSTE G1/8-AG 25	0,143	3,57	5,36	3700	283	90	0...80
FSTE G1/8-AG 50	0,097	2,92	5,34	3700	173	110	0...80
FSTE G1/8-AG 50 VG	0,097	2,92	5,34	3700	173	110	0...80
FSTE G1/4-AG 25	0,711	6,47	15,36	2400	747	145	0...80
FSTE G1/4-AG 25 VG	0,711	6,47	15,36	2400	747	144	0...80
FSTE G1/4-AG 50	0,452	1,40	12,70	2400	466	175	0...80
FSTE G1/4-AG 75	0,262	5,38	15,20	2400	340	190	0...80
FSTE G1/4-AG 75 VG	0,262	5,38	15,20	2400	340	202	0...80
FSTE G1/2-AG 25	3,829	25,64	73,50	4900	1870	400	0...80
FSTE G1/2-AG 75	1,072	37,20	77,40	4900	800	530	0...80
FSTE G1/2-AG 90	1,072	24,38	75,30	4900	730	544	0...80

\*Referred to 50% of operating stroke

\*\*Maximum static loading

\*\*\*The horizontal loading is a maximum static loading and has a negative effect on the in and out movement in a horizontal position

# Spring plungers

## Spring plunger FSTE



### Design data Spring plunger FSTE

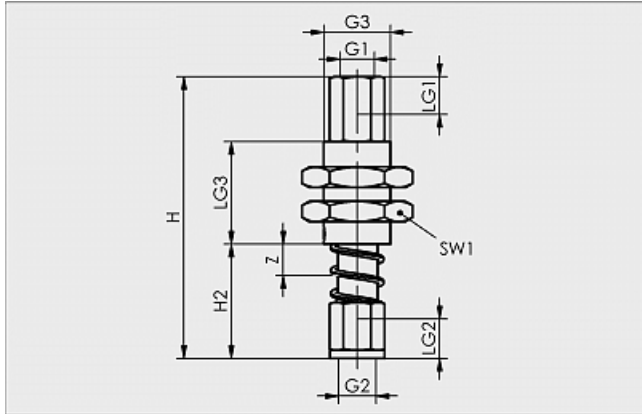

FSTE M3 to M5(-VG)

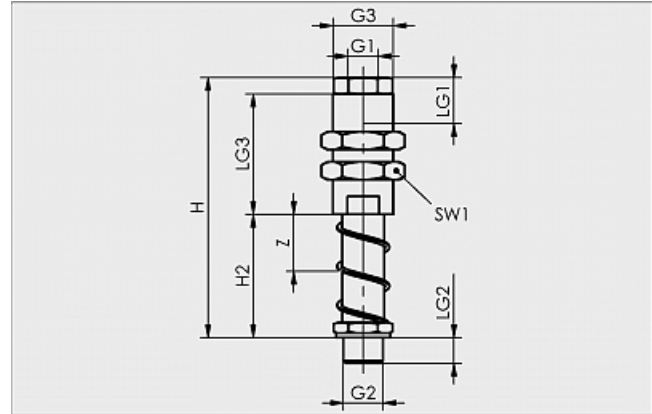

FSTE 1/8 to 1/2(-VG)

Mounting elements  
4

Type	Dimensions in mm									
	G1	G2	G3	H	H2	LG1	LG2	LG3	SW1	Z (Stroke)
FSTE M3-IG 5	M3-F	M3-F	M6x0.75-M	33,5	15,0	3,8	6,0	10	10	5
FSTE M3-IG 5 VG	M3-F	M3-F	M6x0.75-M	33,5	15,0	3,8	6,0	10	10	5
FSTE M5-IG 5	M5-F	M5-F	G1/8-M	41,2	17,0	5,5	6,2	15	14	5
FSTE M5-IG 5 VG	M5-F	M5-F	G1/8-M	41,2	17,0	5,5	6,2	15	14	5
FSTE M5-IG 10	M5-F	M5-F	G1/8-M	47,2	23,0	5,5	6,2	15	14	10
FSTE M5-IG 10 VG	M5-F	M5-F	G1/8-M	47,2	23,0	5,5	6,2	15	14	10
FSTE M5-IG 20	M5-F	M5-F	G1/8-M	59,2	35,0	5,5	6,2	15	14	20
FSTE M5-IG 20 VG	M5-F	M5-F	G1/8-M	59,2	35,0	5,5	6,2	15	14	20
FSTE G1/8-AG 15	G1/8"-F	G1/8"-M	M16x1-M	73,5	29,5	8,0	6,5	30	22	15
FSTE G1/8-AG 15 VG	G1/8"-F	G1/8"-M	M16x1-M	73,5	28,5	8,0	6,5	30	22	15
FSTE G1/8-AG 25	G1/8"-F	G1/8"-M	M16x1-M	86,5	42,5	8,0	6,5	30	22	25
FSTE G1/8-AG 50	G1/8"-F	G1/8"-M	M16x1-M	117,5	73,5	8,0	6,5	30	22	50
FSTE G1/8-AG 50 VG	G1/8"-F	G1/8"-M	M16x1-M	117,5	72,5	8,0	6,5	30	22	50
FSTE G1/4-AG 25	G1/8"-F	G1/4"-M	M20x1.5-M	86,0	40,5	13,0	8,5	40	24	25
FSTE G1/4-AG 25 VG	G1/8"-F	G1/4"-M	M20x1.5-M	86,0	40,5	13,0	8,5	40	24	25
FSTE G1/4-AG 50	G1/8"-F	G1/4"-M	M20x1.5-M	115,5	70,0	13,0	8,5	40	24	50
FSTE G1/4-AG 75	G1/8"-F	G1/4"-M	M20x1.5-M	145,0	99,5	13,0	8,5	40	24	75
FSTE G1/4-AG 75 VG	G1/8"-F	G1/4"-M	M20x1.5-M	145,0	99,5	13,0	8,5	40	24	75
FSTE G1/2-AG 25	G3/8"-F	G1/2"-M	M30x1.5-M	105,5	42,5	13,0	10,5	55	36	25
FSTE G1/2-AG 75	G3/8"-F	G1/2"-M	M30x1.5-M	176,5	113,5	13,0	10,5	55	36	75
FSTE G1/2-AG 90	G3/8"-F	G1/2"-M	M30x1.5-M	188,5	125,5	13,0	10,5	55	36	90