

Magnetic grippers SGM



Magnetic grippers SGM

Our highlights...

- Safe gripping by a permanent magnet
- High holding forces
- Compact design
- Lightweight construction
- Inclusive changeable friction ring
- Can be controlled with compressed-air or a combination of vacuum and compressed-air
- Optional with A1-, A2-, A3 connection adapter sideways (Holder System HTS)
- Facility for connecting two magnetic grippers together into a single block

Your advantages...

- > No electric power required
- > Safe handling also in case of power failure
- > Minimum space required
- > Low overall weight of the handling device
- > Realization of high lateral forces
- > Controlled with pneumatic valves or with compact ejector SMP/SXMP
- > Individual connection possibilities
- > Optimal for long, narrow workpieces



Gripper spider with magnetic grippers SGM being used to handle perforated sheets of metal

Applications

- Handling of perforated metal sheets, complex laser-cut workpieces and metal sheets with holes and apertures
- Handling of ferromagnetic workpieces

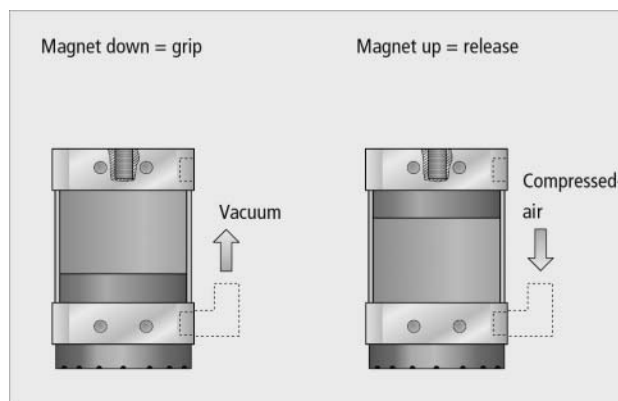

Operation with compact ejector

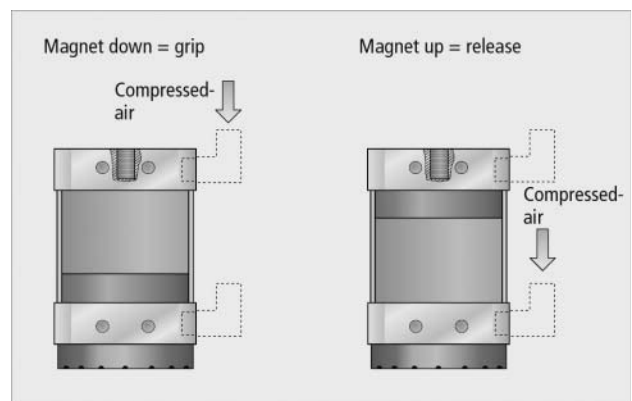

Operation with pneumatic valves and compressed-air

Magnetic grippers SGM

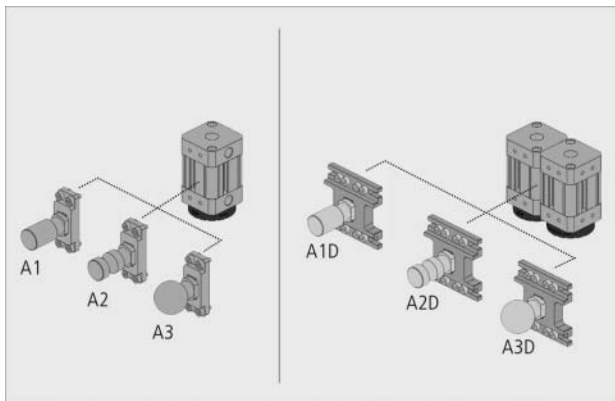

Holder System HTS-A1, -A2, -A3 and Holder System HTS-A1 D, -A2 D, -A3 D

Construction

- Robust aluminium housing with integrated permanent magnet
- Lightweight design
- Clip-on friction ring which can be replaced quickly
- Bistable version: in the case of a power failure, the current function "Grip" or "Release" remains selected
- Standard connection thread in the cover of the magnetic gripper
- Optional mounting facility with the holder system HTS-A1, -A2, -A3 for mounting a magnetic gripper on the gripping system
- Optional mounting facility with the holder system HTS-A1 D, -A2 D, -A3 D for block-mounting of two magnetic grippers on the gripping system
- Mounting threads for the holder systems on three sides



Suitability for branch-specific applications

Designation code Magnetic grippers SGM

Short designation	Diameter in mm	Connection thread
Example: SGM	30	G1/8-IG
SGM	30 40 50 70	G1/8-IG (IG = female) G1/4-IG

Ordering data Magnetic grippers SGM

Type*	Article No.
SGM 30 G1/8-IG	10.01.17.00162
SGM 40 G1/4-IG	10.01.17.00163
SGM 50 G1/4-IG	10.01.17.00164
SGM 70 G1/4-IG	10.01.17.00165

*Note: suitable plug-in screw unions can be found under "Plug-in screw unions" in section 8

Ordering data spare parts Magnetic grippers SGM

Type	Friction ring
SGM 30 G1/8-IG	10.01.17.00136
SGM 40 G1/4-IG	10.01.17.00137
SGM 50 G1/4-IG	10.01.17.00138
SGM 70 G1/4-IG	10.01.17.00139

Magnetic grippers SGM

Ordering data accessories Holder System (single) Magnetic grippers SGM

Type	Holder System HTS-A1*	Holder System HTS-A2*	Holder System HTS-A3*	Sieve**
SGM 30 G1/8-IG	10.01.17.00168	10.01.17.00169	10.01.17.00170	10.05.03.00008
SGM 40 G1/4-IG	10.01.17.00168	10.01.17.00169	10.01.17.00170	10.05.03.00008
SGM 50 G1/4-IG	10.01.17.00171	10.01.17.00172	10.01.17.00173	10.05.03.00008
SGM 70 G1/4-IG	10.01.17.00171	10.01.17.00172	10.01.17.00173	10.05.03.00008

*Mounting screws included

**For operation with pressure/vacuum, order one piece per magnetic gripper

Ordering data accessories Holder System (double) Magnetic grippers SGM

Type	Holder System HTS-A1 D*	Holder System HTS-A2 D*	Holder System HTS-A3 D*	Sieve**
SGM 30 G1/8-IG	10.01.17.00174	10.01.17.00175	10.01.17.00176	10.05.03.00008
SGM 40 G1/4-IG	10.01.17.00174	10.01.17.00175	10.01.17.00176	10.05.03.00008
SGM 50 G1/4-IG	10.01.17.00177	10.01.17.00178	10.01.17.00179	10.05.03.00008
SGM 70 G1/4-IG	10.01.17.00177	10.01.17.00178	10.01.17.00179	10.05.03.00008

*Mounting screws included

**For operation with pressure/vacuum, order one piece per magnetic gripper

Technical data Magnetic grippers SGM

Type	Holding force [N]*	Remaining force [N]	Operating pressure [bar]	Control pressure range [bar]	Installation position	Principle of operation	Operating temperature [°C]	Weight [g]
SGM 30 G1/8-IG	35	0,3	3.5...6	-0,6	Any	Bistable	5...70	130
SGM 40 G1/4-IG	100	0,3	3.5...6	-0,6	Any	Bistable	5...70	240
SGM 50 G1/4-IG	180	0,3	3.5...6	-0,6	Any	Bistable	5...70	440
SGM 70 G1/4-IG	290	0,3	3.5...6	-0,6	Any	Bistable	5...70	715

*Note: The specified value is a static value and does not include a safety factor. When designing systems with magnetic grippers SGM, always use a safety factor of $S = 3$

Design data Magnetic grippers SGM

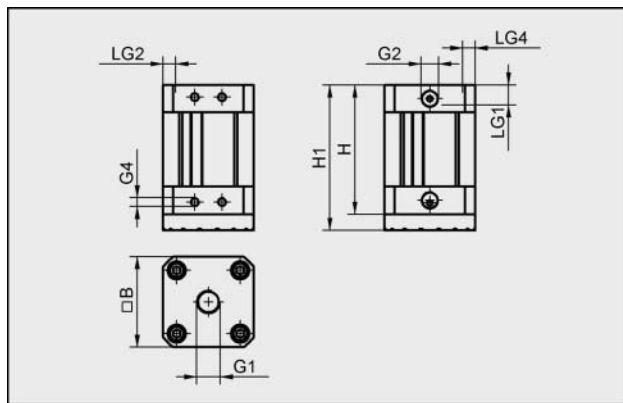

SGM 30 to 70

Type	Dimensions in mm								
	B*	G1	G2	G4	H	H1	LG1	LG2	LG4
SGM 30 G1/8-IG	29,5	G1/8"-F	G1/8"-F	M4-F	61,4	70,2	7	6	5
SGM 40 G1/4-IG	40,0	G1/4"-F	G1/8"-F	M4-F	61,4	70,2	11	6	7
SGM 50 G1/4-IG	50,0	G1/4"-F	G1/8"-F	M5-F	71,4	80,2	11	6	7
SGM 70 G1/4-IG	68,0	G1/4"-F	G1/8"-F	M5-F	71,4	80,2	11	6	8

*Contact surface of the grippers (round) corresponds to dimension B

Magnetic grippers SGM

Design data accessories Magnetic grippers SGM

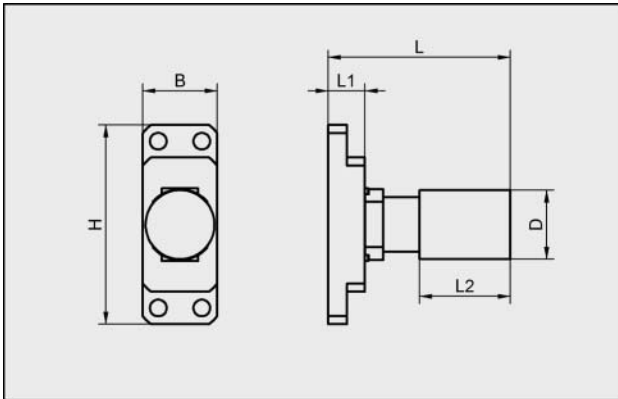

HTS-A1

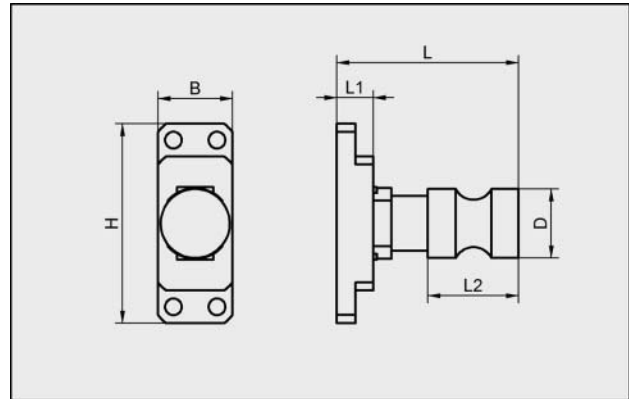

HTS-A2

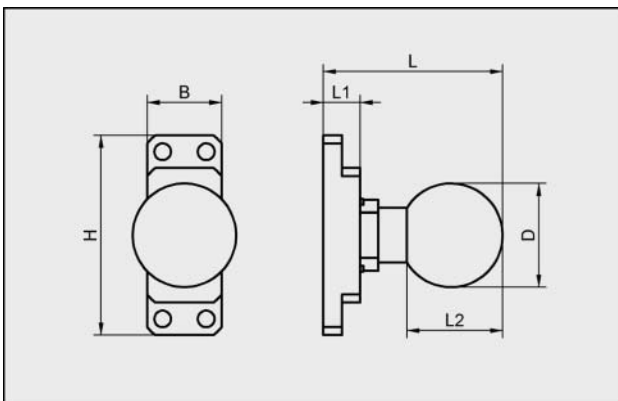

HTS-A3

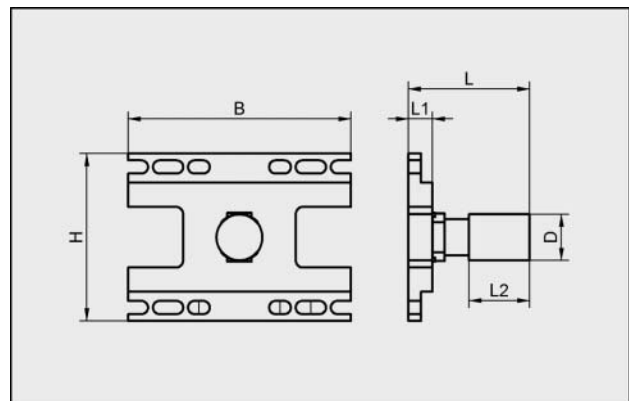

HTS-A1 D

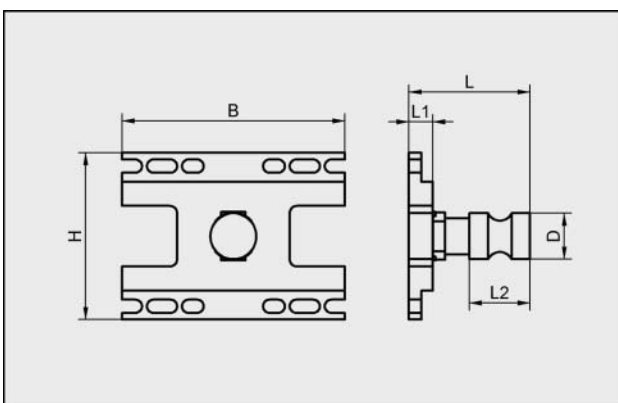

HTS-A2 D

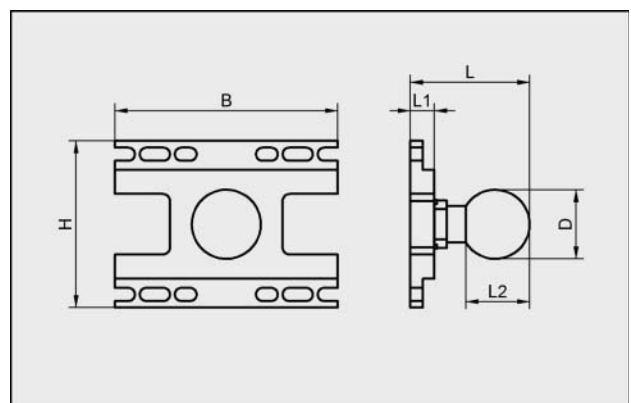

HTS-A3 D

Magnetic grippers SGM



Design data accessories Magnetic grippers SGM

Type	Dimensions in mm					
	B	D	H	L	L1	L2
HTS-A1 SGM 30/40*	20,5	19,0	55	50,2	9,9	25,0
HTS-A2 SGM 30/40*	20,5	19,0	55	50,2	9,9	25,0
HTS-A3 SGM 30/40*	20,5	28,5	55	49,4	9,9	26,4
HTS-A1 SGM 50/70**	26,0	19,0	69	49,9	9,9	25,0
HTS-A2 SGM 50/70**	26,0	19,0	69	49,9	9,9	25,0
HTS-A3 SGM 50/70**	26,0	28,5	69	49,2	9,9	26,4
HTS-A1 D SGM 30/40***	59,0	19,0	59	50,0	9,9	25,0
HTS-A2 D SGM 30/40***	59,0	19,0	59	50,0	9,9	25,0
HTS-A3 D SGM 30/40***	59,0	28,5	59	49,3	9,9	26,4
HTS-A1 D SGM 50/70****	92,0	19,0	69	50,0	9,9	25,0
HTS-A2 D SGM 50/70****	92,0	19,0	69	50,0	9,9	25,0
HTS-A3 D SGM 50/70****	92,0	28,5	69	49,3	9,9	26,4

*suitable for 1 SGM 30 or 1 SGM 40

**suitable for 1 SGM 50 or 1 SGM 70

***suitable for 2 SGM 30 or 2 SGM 40

****suitable for 2 SGM 50 or 2 SGM 70