Suction pads

Suction pads from Schmalz are subdivided into universal suction pads and suction pads for specific branches and applications. The universal suction pads cover a wide range of requirements, while the suction pads for special branches and applications are designed to meet special requirements and are characterised by special properties, such as the handling of thin bodywork parts in the automotive industry or of porous workpieces in the woodworking industry.

In general, a distinction is made between the following shapes:

- Flat suction pads
- Bellows suction pads

Each version has its own specific advantages, which can be improved or optimised by the use of suction pads made of various materials. Detailed explanations of the available suction pad materials can be found after the section "Selection and Configuration".



Flat suction pads

Flat suction pads are particularly suitable for the handling of objects with flat or only slightly curved surfaces. Due to their flat shape, they can grip the workpiece in a very short time and can withstand the forces which result from fast movement of the object during handling.

Advantages of flat suction pads

- Wide range of suction pads made from various materials and with differing sizes and shapes (round, oval, with steep or flat sealing lip)
- Low overall height and the resulting minimum internal volume ensures very short evacuation times
- Suitable for high lateral forces
- Good intrinsic stability when attached to the load

Typical applications

- Handling of smooth or slightly rough workpieces such as metal sheets, cardboard boxes, sheets of glass, plastic parts and sheets of wood



Bellows suction pads

Bellows suction pads are used when it is necessary to compensate for varying workpiece heights, to handle parts with uneven surfaces or to handle easily-damaged parts.

Advantages of bellows suction pads

- Good adaptation to uneven workpiece surfaces
- Lifting effect during evacuation
- Compensation for height differences
- Careful gripping of easily damaged workpieces

Typical applications

- Handling of curved or uneven workpieces such as car body work components, pipes, cardboard boxes etc.
- Handling of easily damaged workpieces such as electronic components, injection-molded plastic parts etc.
- Handling of products packed in boxes or blister-packs



Both types of suction pads are available in a wide range of shapes and sizes. The table of contents for this section contains more basic data and information about the application areas for the various suction pad types.

Explanation of the technical data (does not apply to grippers with special functions)

Various calculations must be made for the various components during the planning of a vacuum system. The following sections explain the most important technical data of the suction pads in order to simplify system design. These explanations do not apply to the special suction pads in Section 3.

Theoretical suction force

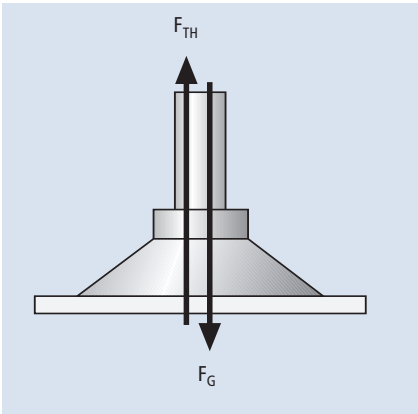

The theoretical value in N at a vacuum of -0.6 bar (at sea level). Depending on the operating conditions, this value may have to be reduced in order to take the necessary safety factor, the losses due to friction or a lower vacuum value (due, for example, to a porous workpiece).

Lateral force

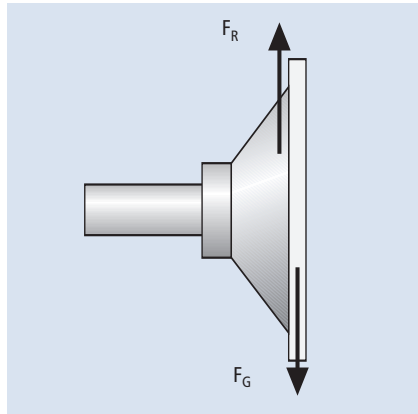

The measured value in N at a vacuum of -0.6 bar on a dry or oily, flat and smooth workpiece surface. These values do not include a safety factor.

Internal volume

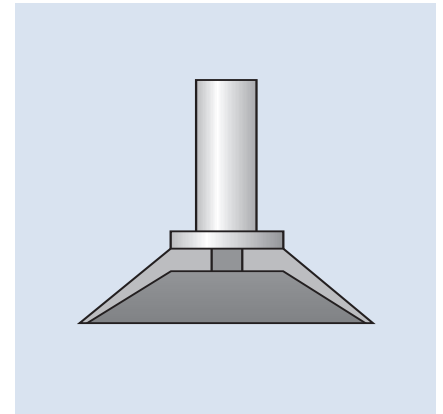

This is used to calculate the total volume of the gripper system and also affects the calculation of the evacuation time.

Minimum radius of curvature of the workpiece

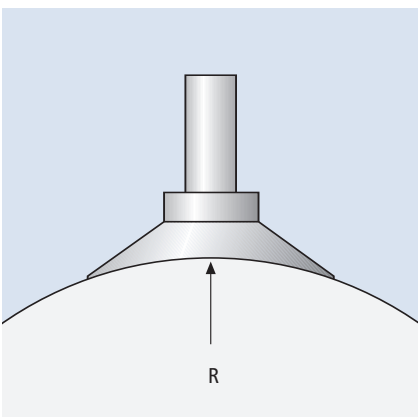

This specifies the minimum radius at which the workpiece can be gripped securely by the suction pad.

Suction pad stroke

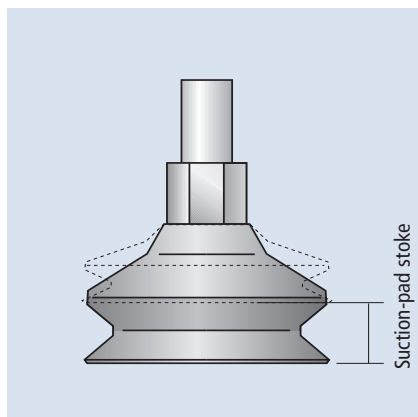

This is the lifting effect which occurs during evacuation of the suction pad.

Suction pad selection

The selection of the suction pad always depends on the actual application (the operating conditions and the material). For this reason, various physical values must be calculated and determined before the correct suction pad can be selected.

Coefficient of friction

It is not possible to specify generally valid values of the coefficient of friction "μ" between the suction pad and the workpiece. This means that this value must be determined beforehand by means of suitable tests (see also the table of typical values).

Table of typical values

Workpiece surface	approx. μ
Glass, stone, plastic (dry)	approx. 0.5
Sandpaper (dry)	1.1
Moist or oily surface	0.1 – 0.4

Calculation of the holding forces

The calculated holding forces can never be more than theoretical values. In practical applications, many factors, such as the size and shape of the suction pad, the surface finish and the rigidity of the workpiece (deformation) play a decisive role. For this reason, we recommend that you include a safety factor S of at least 2. The German accident-prevention regulations demand a minimum safety factor of 1.5.

If you intend to swivel or turn over the workpiece, you should use a safety factor of 2.5 or higher in order to cope with the resulting turning forces.

The holding force of a suction pad is calculated with the formula $F = p \times A$

Suction pad diameter

The diameter of the suction pad is important for the absolute holding force and also depends on the finish of the workpiece surface. The required diameter can be determined with the aid of the following formula.

With the force applied horizontally:

$$d = 1.12 \cdot \sqrt{\frac{m \cdot S}{P_U \cdot n}}$$

With the force applied vertically:

$$d = 1.12 \cdot \sqrt{\frac{m \cdot S}{P_U \cdot n \cdot \mu}}$$

d = suction-pad diameter in cm,
(with double lip ≈ internal diameter,
for bellows suction pad = internal diameter of the sealing lip)

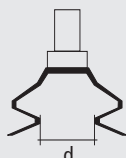

m = mass of the workpiece in kg
 P_U = vacuum in bar
 n = number of suction pads
 S = safety factor
 μ = coefficient of friction

An example:

Plastic sheet: m = 50 kg
 Vacuum: $P_U = -0.4$ bar
 Number of suction pads: n = 4
 Measured coefficient of friction: μ = 0.5
 Safety factor: S = 2

$$d = 1.12 \cdot \sqrt{\frac{50 \cdot 2}{0.4 \cdot 4 \cdot 0.5}}$$

$$d = 12.5 \text{ cm}$$

A good solution in this case is the suction pad PFYN 150 with a nominal diameter of 150 mm.

Suction capacity [∇]

The desired vacuum value and the volume flow rate used to achieve this vacuum are decisive for calculation of the necessary suction capacity. The workpiece material is the decisive factor which determines the necessary suction capacity. The table shows typical values for the volume flow rate and the suction capacity for various suction pad diameters.

Typical value (with smooth, air-tight surfaces)			
Suction pad Ø	Suction area A [cm²]	Volume flow ∇ [m³/h]	[l/min]
up to 60 mm	28	0.5	8.3
up to 120 mm	113	1.0	16.6
up to 215 mm	363	2.0	33.3
up to 450 mm	1540	4.0	66.6

Important:

For porous parts, you should always carry out suction tests!

Vacuum suction pads

Selection and configuration



Planning checklist for selection of suction pads

What are the dimensions and weight of the workpiece?	These are important for calculation of the suction force and the number of suction pads (see the technical information).
What is the surface finish of the workpiece (rough, structured, smooth)?	This determines the type of suction pad (material, shape, dimensions).
Could the workpiece be dirty? If so, what kind of dirt?	This is important for the dimensioning of the suction pad (see the technical information) and for the design of the dust filter.
What is the maximum temperature of the workpiece?	The temperature is important for selection of the suction pad material. Special materials may be necessary for temperatures higher than 70 °C (see materials table).
Is precise positioning for picking up or placing of the workpiece required?	This determines the type, version and shape of the suction pad.
What cycle times are used?	This is important for the dimensioning and plays a part in the calculations (suction force of the pad etc.). See the technical information.
What is the maximum acceleration during handling?	This may affect the dimensioning and plays a part in the calculations (suction force, moment of inertia etc.). See the technical information.
What type of handling is needed (moving, slewing, turning over)?	This is required for calculation of the suction force and for design of the system.
Which environmental effects do exist?	These are important for selection of the suction pad material (resistance to ozone and other chemicals, silicone free etc.).

Vacuum suction pads

The material is decisive



Material overview

Chemical designation	Nitrile rubber		Silicone rubber		Natural rubber	High temp. material	Polyurethane
	Trade name	Perbunan (AS = antistatic)	Silicone (AS = antistatic)	Silicone (AS = antistatic)			
Abbreviation	NBR	NBR-AS	SI	SI-AS	NK	HT1	PU
Wear resistance	●●	●●	●	●	●●	●●●	●●●
Resistance to permanent deformation	●●	●●	●●	●●	●●●	●●	●
General weathering resistance	●●	●●	●●●	●●●	●●	●●●	●●●
Resistance to ozone	●	●	●●●●	●●●●	●●	●●●●	●●●
Resistance to oil	●●●●	●●●●	●	●	●	●●●●	●●●
Resistance to fuels	●●	●●	●	●	●	●●	●●
Resistance to alcohol, ethanol 96%	●●●●	●●	●●●●	●●	●●●●	●●●●	●●●●
Resistance to solvents	●●	●●	●●	●●	●	●●	●
General resistance to acids	●	●	●	●	●●	●	●
Resistance to steam	●●	●●	●●	●●	●	●●●	●
Tensile strength	●●	●●	●	●	●●	●●	●●●
Abrasion value in mm ³ to DIN 53516 (approx.)	100–120 at 55 Sh.	100–120 at 55 Sh.	180–200 at 55 Sh.	180–200 at 55 Sh.	100–120 at 40 Sh.	100–120 at 60 Sh.	60–80 at 55 Sh.
Specific resistance in [Ω · cm]	–	≤ 10 ⁷	–	≤ 10 ⁷	–	–	–
Short-term temperature* resistance in °C (< 30 sec.)	-30° to +120°	-30° to +120°	-50° to +220°	-35° to +220°	-35° to +120°	-30° to +170°	-40° to +130°
Longer-term temperature resistance in °C	-10° to +70°	-10° to +70°	-30° to +180°	-20° to +180°	-25° to +80°	-10° to +140°	-30° to +100°
Shore hardness to DIN 53505	40 to 90	55 ± 5	30 to 85**	55 ± 5	30 to 90	60 ± 5	55
Colour / coding	black, grey, blue, light blue	black	white, translucent	black	grey, light brown, black	blue	blue, green

* Approximate value: depends on ambient temperature, application force and recovery time

** After-bake of silicone 10 h/160 °C = + 5 ... 10 Shore A

●●●● excellent

●●● very good

●● good

● poor to satisfactory

Selection aid for suction pad materials

Anwendungen	NBR	NBR-AS	SI	SI-AS	NK	HT1	PU
Branch-specific applications	Universal application	Universal application	CD/DVD Packaging Plastics	CD/DVD Packaging Plastics	Wood Packaging	Plastics	Packaging
Foodstuff quality			☑				
Oily workpieces	☑	☑				☑	☑
No marking of workpieces						☑	
Slight marking of workpieces	○	○	☑	☑	☑		☑
Higher temperatures			☑	☑		☑	
Lower temperatures			☑	☑	☑		
Very heavy loads							☑
Very smooth surfaces (glass)	☑						☑
Rougher surfaces (wood, stone)					☑		☑

○ grey version with little marking

Vacuum suction pads

The material is decisive



Material overview

Vulkollan	Polyvinyl chloride	Fluorcaoutchuc (AF = no making)		Chloroprene	Ethylene-propylene-rubber
VU 1	PVC	FPM	FPM-AF	CR	EPDM (foam r.)
●●●●●	●●●●	●	●	●●	●
●●	●	●●●●	●●●●	●●	●●
●●●●	●●	●●●●●	●●●●●	●●●●	●●●●●
●●●●	●●●●	●●●●●	●●●●●	●●●●	●●●●●
●●●●	●●●●	●●●●●	●●●●●	●●●●	●●●●●
●●	●	●●●●●	●●●●●	●●●●	●●***
●●●●●	●	●●	●●	●	●
●	●	●●●●	●●●●	●●●●●	●●●●●
●	●●	●●●●	●●●●	●●	●●
●	●●●●	●●	●	●●	●●●●
●●●●●	●●	●●	●●	●●	●
10–12 at 72 Sh.	100–120 at 50 Sh.	200–210 at 65 Sh.	200–210 at 65 Sh.	120–140 at 60 Sh.	Not suitable for foam rubber
–	–	–	–	–	–
-40° to +100°	-30° to +65°	-10° to +250°	-10° to +250°	-40° to +100°	-35° to +130°
-40° to +80°	-15° to +50°	-10° to +200°	-10° to +200°	-20° to +70°	-25° to +100°
72	50	65 ± 5	65 ± 5	20–60	~15****
dark green	blue, translucent	black	black	black, grey	black

*** With slight oil wetting
**** Varies, for technical reasons, for foam rubber

The application and the ambient conditions are decisive for the selection of the appropriate suction pad material. In many cases, for example, the application demands resistance to abrasion, resistance to oil or suitability for use with foodstuffs.

The overview summarizes the properties of various suction pad materials and shows typical applications for which the materials are particularly suitable.

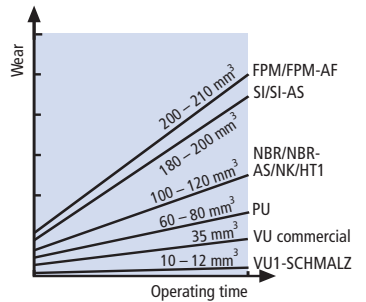

Note: we recommend the use of commercially available soap solution for cleaning suction pads

Selection aid for suction pad materials

VU 1	PVC	FPM	FPM-AF	CR	EPDM (foam r.)
Metal	Packaging	Typical application for high temperature	Typical application for high temperature	Metal	Metal
Wood	CD/DVD			Wood	Wood
Packaging					
<input checked="" type="checkbox"/>	<input checked="" type="checkbox"/>	<input checked="" type="checkbox"/>	<input checked="" type="checkbox"/>		
			<input checked="" type="checkbox"/>		
<input checked="" type="checkbox"/>				<input checked="" type="checkbox"/>	
		<input checked="" type="checkbox"/>	<input checked="" type="checkbox"/>		
<input checked="" type="checkbox"/>	<input checked="" type="checkbox"/>				
<input checked="" type="checkbox"/>		<input checked="" type="checkbox"/>	<input checked="" type="checkbox"/>		
<input checked="" type="checkbox"/>					<input checked="" type="checkbox"/>

Suction pads accessories



Spring plungers (FSTE/FSTA/FSTI/FSTF)

Are used for spring-mounting of suction pads, particularly in fully automatic systems, to ensure that the pads can be placed carefully, even on easily damaged workpieces. Spring plungers also compensate for varying workpiece heights. Further information in Section 4.



Sensing valves (TV)

Can be screwed into many suction pads with screw nipples. They sense whether a workpiece is in contact with the pad and open the vacuum line only if this is so. Further information in Section 6.



Adapter nipples (ANW/AN)

Are used for rigid mounting of suction pads on, for example, a cross-beam or for mounting with a spring plunger. The vacuum connection is on the side. Further information in Section 4.



Flow resistors (SW)

Reduce the cross-sectional area of the vacuum and thus help to maintain the system vacuum if one or more suction pads are not in contact with the workpiece. The vacuum line is not fully closed. They are particularly suitable for the handling of porous workpieces. Further information in Section 6.



Ball joints and Flexolink (KGL/FLK)

Are screwed onto the suction pads to permit a certain amount of flexibility. They permit optimum adaptation of the pad to uneven workpieces. Further information in Section 4.



Check valves (SVK/SVKG/SVV/SVN)

Continuously measure the rate of flow of air through themselves. If one or more suction pads are not in contact with the workpiece, or if the workpiece is pulled away, they close in order to maintain the vacuum in the rest of the system. Type SVN is even suitable for use on porous workpieces. Further information in Section 6.



Sealing rings (DR)

Robust PA sealing rings with excellent sealing properties. Further information in Section 8.